



Newton

THE CONTEMPORARY STOVE COLLECTION



Generations of heating comfort

The Trianco name has its roots in the 1800's when Newton Chambers & Co., one of Britain's great manufacturing companies, began production of cast iron cooking ranges at its giant Thorncliffe complex near Sheffield, then later as the Redfyre range of solid fuel fires, boilers and cookers.



In the 1960's, under the Trianco- Redfyre brand, production was extended to include oil-fired heating boilers. Reflecting its position as market leaders the company was awarded the Royal Warrant to HM The Queen Mother.

Today the Trianco range of quality heating products is still designed and manufactured on the original Thorncliffe site and includes solid fuel boilers and stoves, electric boilers, oil boilers and air source heat pumps.

The company today, as in the past, is constantly striving to address the changes and challenges of a modern world, innovating and developing products that provide efficient and reliable heating, whilst respecting the worlds' resources and environment.



Real flame heating with a superb pedigree

The appeal of solid fuel heating has never been greater. With global and economic events creating uncertainty over fuel supplies many people are attracted to sourcing local fuels and taking control of their comfort, and budget. Any environmental impact of solid fuel heating is minimised, when timber is sought from a fully managed sustainable source, wood is then recognised as a truly renewable fuel.

The Trianco solid fuel range benefits from the expertise and knowledge gained from decades of manufacturing this type of heating appliance. All products are manufactured at our Thorncliffe site in Sheffield using quality steel and materials to provide years of reliable and economical service.

Whether you choose one of our Newton stoves as a stunning centre-piece to give the warmth and beauty of real flame heating or our TRH solid fuel roomheater to provide reliable and efficient full house central heating, you can be assured of making a solid investment that will endure for years.



Newton 5kW shown in Matt Black



The TRH inset room heater

5kW Clarat enamel



Newton Stoves

Contemporary styling is combined with traditional construction to create a high quality compact stove carefully designed to burn wood, solid fuels, peat and briquettes, effectively and efficiently.

Manufactured with high quality plate steel Newton stoves exceed all current standards and a long life without deterioration is assured.

The range of models cover 5 and 8kW outputs, available as floor standing or with a pedestal base.

Boiler versions of the 8kW model can provide over 5kW of heating output to supply radiators and hot water.

Newton stoves feature a 'triple-burn' system where tertiary air is introduced to ensure a cleaner and more efficient combustion for lower emissions. The built in adjustable 'air-wash' system maintains a clear view of the living flame by preventing deposits on the door glass.

Newton's stunning looks are completed with a beautifully finished stainless steel door handle, air controls and external 'riddling' bar for ash clearance without opening the door.

As well as the standard matt black, a matt ivory paint finish and a range of six colours in a lustrous vitreous enamel are available, enabling you to create a beautiful centre-piece for any room.





Newton

5kW stove

Contemporary styling is combined with traditional construction to create a high quality compact stove carefully designed to burn wood, solid fuels, peat and briquettes, effectively and efficiently. (Jet Black enamel shown).



Newton

5kW stove with pedestal

Available as 5kW and 8kW pedestal options. The extra storage space serves as a useful fuel store and elevates the warmth and flame view to seating level.

5kW Cream enamel



Inside Newton

Fitted with vermiculite bricks to encourage retention of heat. Also fitted with 5mm steel baffle plate which prolongs the life of the stove.

Unique handle design

Newton features a unique and ergonomically designed knurled handle, crafted out of stainless steel. It's design gives the handle an 'easy grip' feel that is finished off to perfection complementing the contemporary finish of the stove.

Accessories

High quality accessories include a cast iron fire grate, ash pan and operating tool and to simplify installation, the option of top or rear flue connections (boiler - top only) are available.





Newton

8kW boiler stove

Boiler versions of the 8kW model can provide over 5kW of central heating output to supply radiators and hot water. Also available as pedestal model.



TRH 45

Inset room heater

The TRH is a real beauty and beast. It offers a real fire that can burn a selection of smokeless solid fuels to ultimately give a cosy flicker of a real flame and a snug feeling to any living room. It is also a real powerhouse with a hidden central heating back-boiler, a total heat output of over 13kW is available with 1.9kW of this heat emitted into the room, easily enough to heat a small home completely or make a significant contribution in larger properties where several heat sources can be combined.

Fitting conveniently into a standard fireplace opening the TRH has a beautiful contemporary design with stainless steel

handle and primary air control mimicking the Newton stove design; functionally an adjustable thermostatic control provides efficient operation tailored to your demands and conditions.

The thermostatic control coupled with a generous firebox capacity means that overnight or long periods of burning are possible and an external riddling feature further simplifies operation.

The TRH is finished in matt Black with a large toughened glass window.

ENVIRONMENTAL SENSE

Burning logs on your Newton stove means your home is being provided with heat from a natural and sustainable source at low emission levels. Wood is a better source of fuel in environmental terms when compared with fossil fuels such as oil and gas that have a negative impact on climate change. Using wood as a fuel also means less dependence on energy companies and easier control of the cost of your fuel.

Regeneration

The burning of wood is a carbon neutral process, through combustion it produces carbon dioxide, the very same element it absorbs from the air during growth. Burning seasoned hard wood is recommended for maximum efficiency.

Wood burning

Following successful testing to the 'defra' standard, the Newton range of stoves are approved to burn wood in smoke control areas. Use of a Defra approved Newton stove ensures wood burning can take place legally and safely in all cities throughout the UK.

For more information and a list of the areas that have been designated a "Smoke Control Zone" please visit: www.uksmokecontrolareas.co.uk.

Solid fuel burning

Solid fuel is a fantastic fuel option that brings many advantages. It is efficient and economical and can

provide your home with better ventilation than an average house. It can also encourage the reduction of condensation and household mould build up which is often associated with 'on/off' fires.

Newton stoves can burn a selection of manufactured and natural smokeless fuels such as bituminous coal briquettes. For a full list of suitable fuels, please check with the official solid fuel approvals body, HETAS: www.hetas.co.uk or the Solid Fuel Association. Only use fuels approved for use with closed heating stoves.



8kW in Matt Black shown with pedestal



Pewter



Royal Blue



Jet Black



Claret



Cream



British Racing Green

Colour your living space

Vitreous enamel

Vitreous enamel gives a stove a beautiful high quality finish that is durable and easy to clean. A choice of six stunning colours are available to suit the décor of your home, from classic Cream and Claret to more contemporary Pewter and Jet Black. Available on 5kW standard model only

Ivory matt finish

Ivory matt is simply chic, complementing any room with its light subtle finish this beautiful colour accentuates the fine lines of the Newton. Available on all models.

Please note: Whilst every effort has been made to display colours as accurately as possible it is for guidance purposes only.



5kW in Ivory Matt with pedestal

Dimensions & specifications



Newton

Model	Nominal Max Output space kW (wood)	Nominal Max Output water kW (wood)	Net Efficiency (% wood)	Dimensions mm (W x D x H)	Flue outlet Diameter mm	Height to rear flue centre	Distance rear to top centre	Max log length mm	Flow and return connections	Defra approved model	Vitreous Enamel finish (6 colours)	Matr Ivory finish
5kW	4.8	-	78.9	390 x 300 x 540	127	430	115	300	-	Yes	Yes	Yes
5kW Pedestal	4.8	-	78.9	390 x 300 x 780	127	670	115	300	-	Yes	-	-
8kW	8.3	-	75.1	540 x 360 x 540	152	430	154	300	-	Yes	-	-
8kW Pedestal	8.3	-	75.1	540 x 360 x 780	152	670	145	440	-	Yes	-	-
8kW Boiler	3.4	5.3	73.8	540 x 360 x 540	152	-	145	440	1" BSP	Pending	-	-
8kW Boiler Pedestal	3.4	5.3	73.8	540 x 360 x 780	152	-	145	440	1" BSP	Pending	-	-

TRH Inset Room Heater

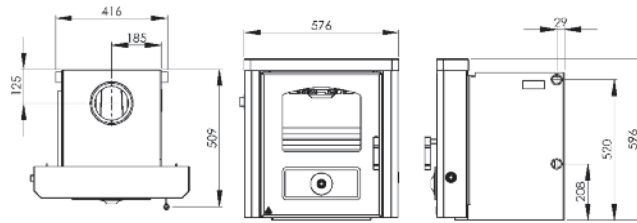

Model	Nominal Max Output space kW	Nominal Max Output water kW	Net Efficiency	Dimensions mm (W x D x H)	Flue outlet Diameter mm	Height to rear flue centre	Distance rear to top centre	Max log length mm	Flow and return connections	Defra approved model	Vitreous Enamel finish (6 colours)	Matr Ivory finish
13kW	1.9	11.4	68.4	577 x 476 x 596	127	-	125	-	4 x 1" BSP	-	-	-

Features

1. Top and rear flue connection
2. Secondary air
3. 5mm steel body and door
4. 5mm steel throat plate
5. Vermiculite fire brick
6. Cast iron inner and outer grate
7. Primary air
8. Riddling lever

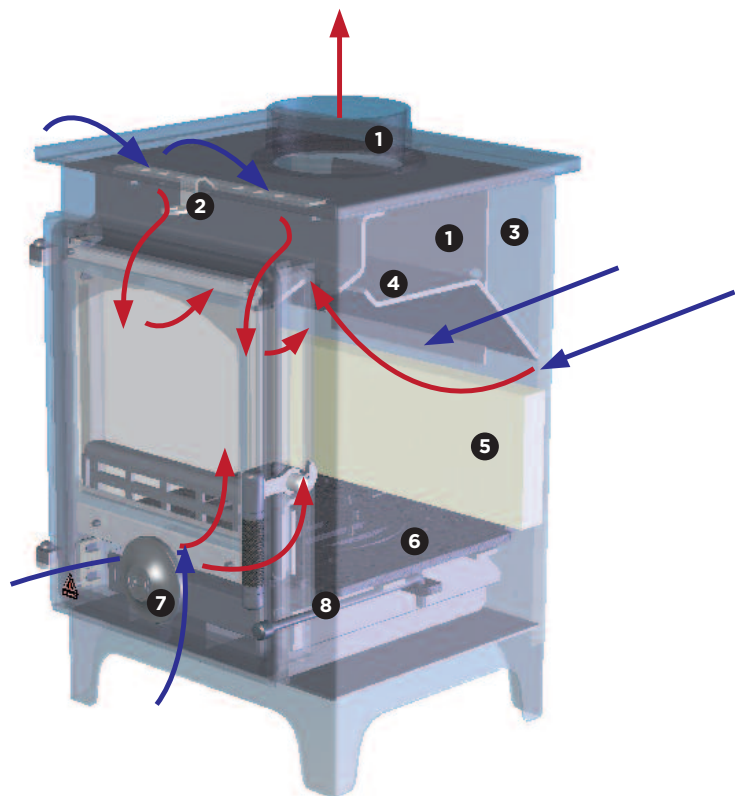

Typical system layout - Newton Boiler model

This system arrangement shows the Newton 8kW boiler model supplying heat to a typical radiator layout. The main source of heating supply can then become a back-up to an existing heating system. Less reliance on one source of supply can mean lower energy bills as a result.

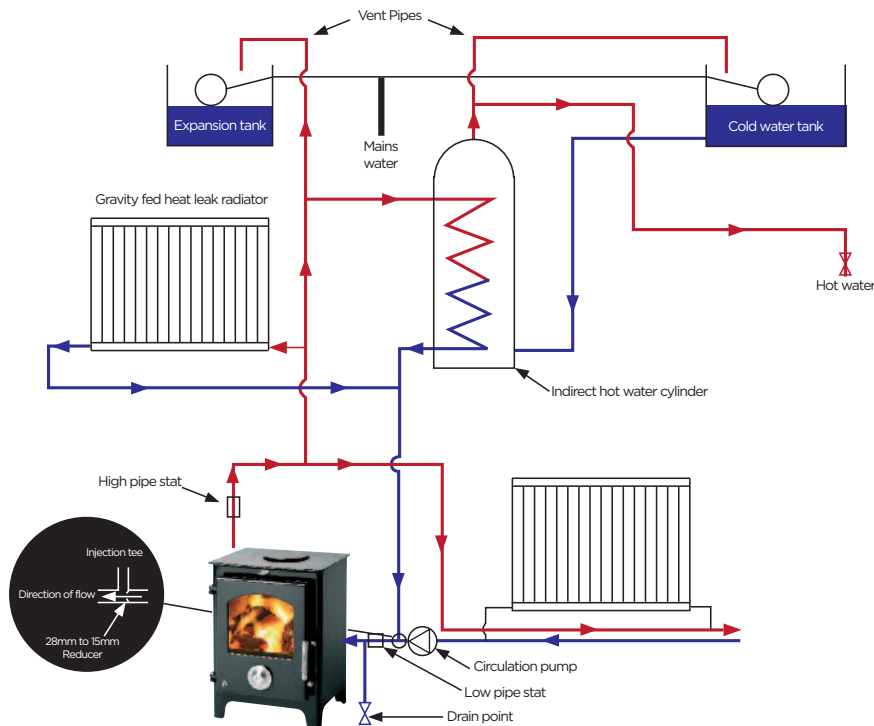

Typical system layout - TRH Inset roomheater

Capable of supplying a 2/3 bedroomed property the TRH can provide 13kW of output (combined heat/water) efficiently when combined with an existing heating system or can act as an independent supply.

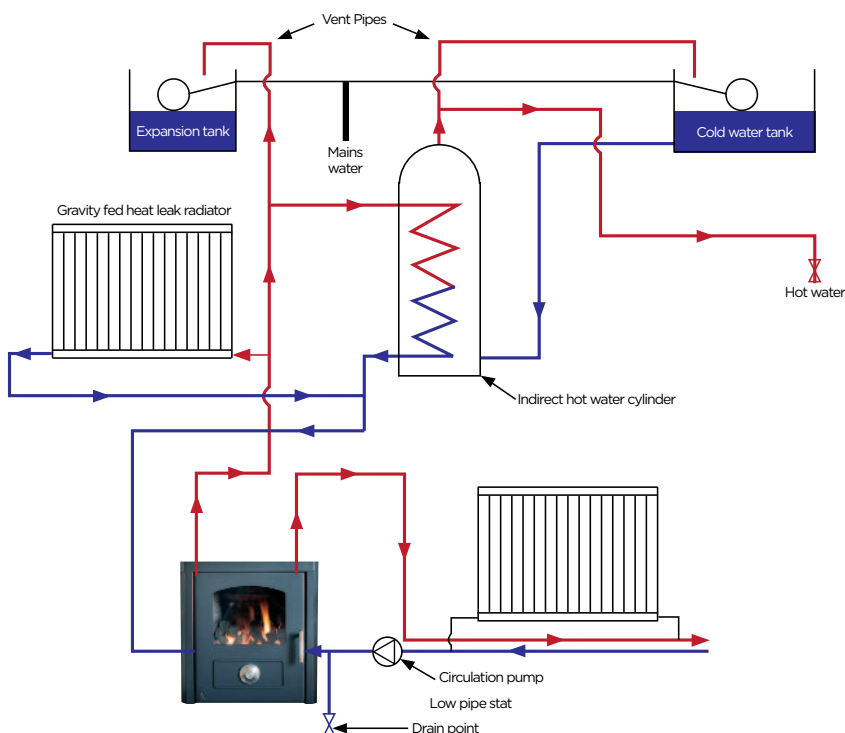



Your local stockist

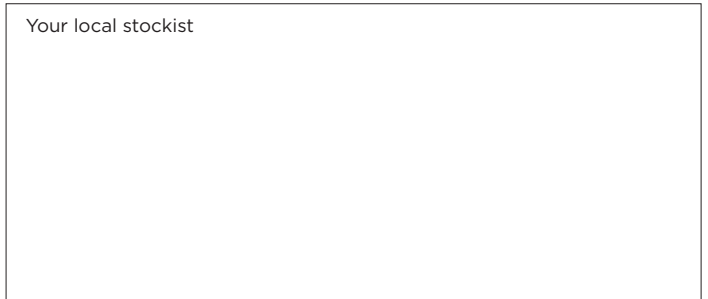

Copyright of all contents of this leaflet is vested in TR Engineering Limited. Any part may not be reproduced without permission. The contents of this leaflet are accurate at the date of printing but, because TR Engineering has a policy of continual development, it may be superseded and should be disregarded if specifications or appearances are changed. The statutory rights of the customer are not affected. E&OE's



Newton
THE CONTEMPORARY STOVE COLLECTION



Adina
Unit E • Fairview Buildings
Heage Road Industrial Estate • Ripley
Derbyshire • DE5 3GH
Tel: 01773 571330 • Fax: 01635 201737
Email: sales@adinaheating.co.uk
www.adinaheating.co.uk

Adina is the UK's exclusive distributor of the
Newton COLLECTION
docherty mmf icl adina surefire
» Specialist distributor of flues, chimneys & renewable appliances



TR Engineering Limited is a company registered in England and Wales with company reg no 7321802 XC990829 05/13 issue 02

A market leading range of heating products from Trianco